

Ver-tech V63HD Baling Press

Our flagship machine, the standard V63HD baler is designed for use in retail stores, manufacturing plants, warehouses, distribution centers or any location producing refuse paper and plastic.

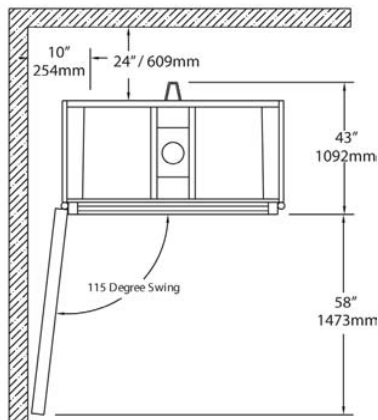
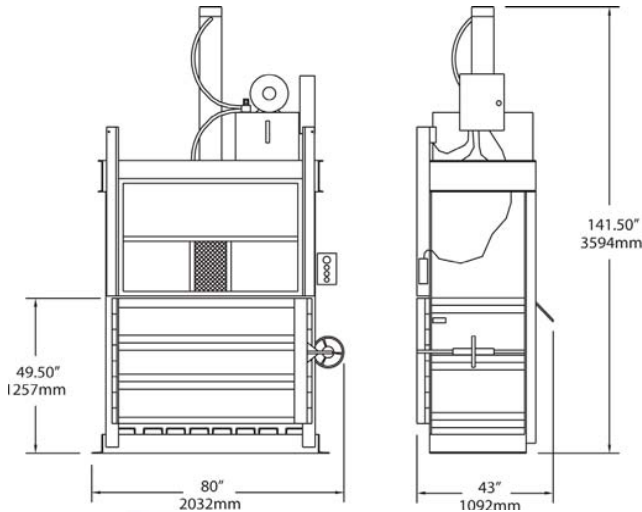

AVAILABLE OPTIONS:

- Slotted Front Door
- Wire Guides
- Rear Feed Opening/Front Eject
- Feed Chute
- Counter Weighted Bale Retainer Dogs
- Weather Proof Package
- Oil Heater
- Full Bale Light

SPECIFICATIONS

PERFORMANCE

Nominal Bale Size	60" x 30" x 48"
Bale Weight	Up to 1100 lbs. OCC
Bale Volume	50 cu. ft.
Number of Bale Tie Slots	6
Compact Force lbs. - Normal/Maximum	62,202/67,857
Platen Pressure	38 PSI
Average Cycle Time	46 Seconds
Loading Height	49.5"
Ejector System	Semi-Automatic
Bale Full Switch	Standard

HYDRAULIC/ELECTRICAL

Motor HP	15
Voltage 3 Phase	208, 230, 480
Pump GPM	12.8
Normal System Pressure PSI	2200
Max. System Pressure PSI	2400
Cylinder Bore x Stroke	6" x 48"
Hydraulic Tank-Capacity Gallons	22

ETL certified with UL listed controls and meets or exceeds ANSI standard Z245.5.



Ver-tech Inc.

6801 Bleck Drive. Rockford, Minnesota 55373 Telephone
(763) 559-2590 TOLL FREE (800) 328-3398

FAX (763) 559-1438

For more information, visit us at <http://www.ver-tech.com>

V63HD-1203VT